

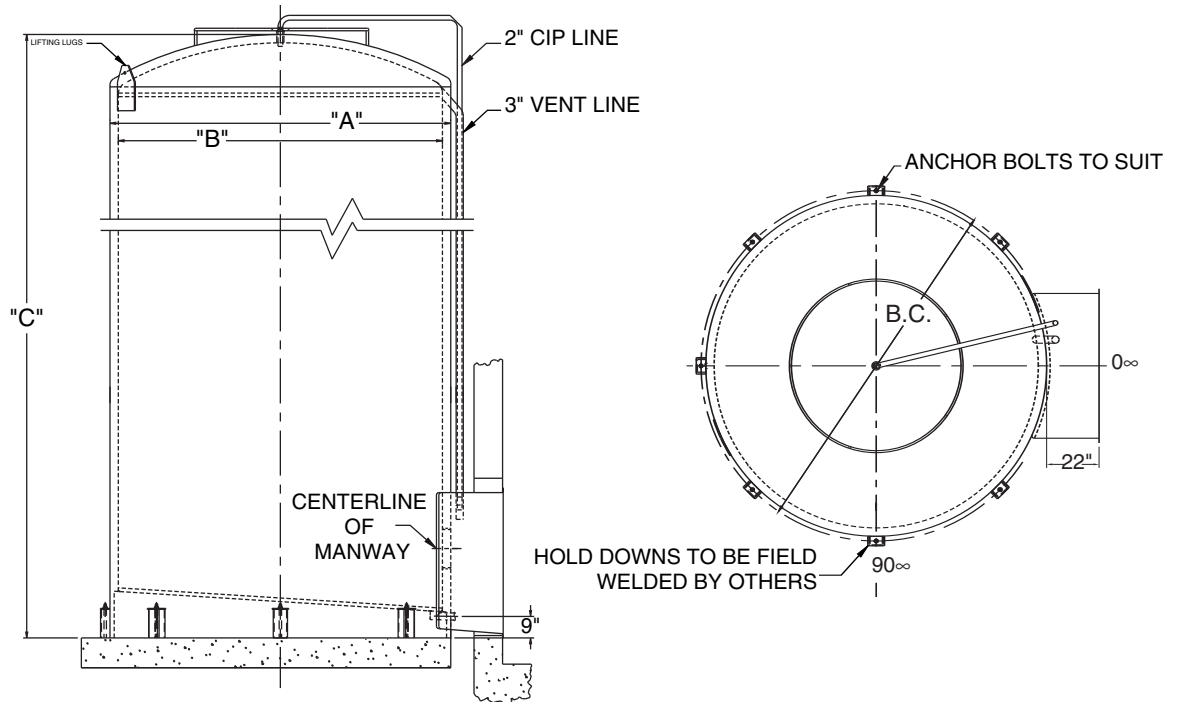

# S P E C I F I C A T I O N S F O R V E R T I C A L S I L O S



## STANDARD SIZE-ALL SILOS CONFORM TO 3A STANDARDS

Nominal Capacity (gallons)	A Wrap Outside Diameter	B Liner Inside Diameter	Liner Shell Height	C Overall Height (Approx.)	BC Bolt Circle Diameter	Standard Number of Anchors	Approx. Weight (Lbs.)
6,000	115"	108"	13'-6"	16'-3"	119"	4	7,000
8,000	115"	108"	18'-0"	20'-9"	119"	4	8,300
10,000	121"	114"	20'-0"	22'-10"	125"	6	9,725
10,000	127"	120"	18'-0"	20'-10"	131"	6	10,300
10,000	143"	136"	14'-0"	16'-11"	147"	6	11,900
12,000	131"	124"	20'-0"	22'-11"	135"	6	12,000
15,000	133"	126"	24'-0"	26'-11"	137"	6	13,300
15,000	143"	136"	21'-0"	23'-11"	147"	6	14,500
20,000	143"	136"	28'-0"	30'-11"	147"	7	17,400
25,000	143"	136"	34'-0"	36'-11"	147"	7	18,400
30,000	143"	136"	41'-0"	43'-11"	147"	7	19,500
40,000	143"	136"	54'-0"	56'-11"	147"	7	27,400
50,000	143"	136"	67'-0"	69'-11"	147"	7	33,500
60,000	151"	144"	72'-0"	75'-0"	155"	7	40,800
70,000	151"	144"	85'-0"	88'-0"	155"	7	48,000



# S P E C I F I C A T I O N S F O R V E R T I C A L S I L O S

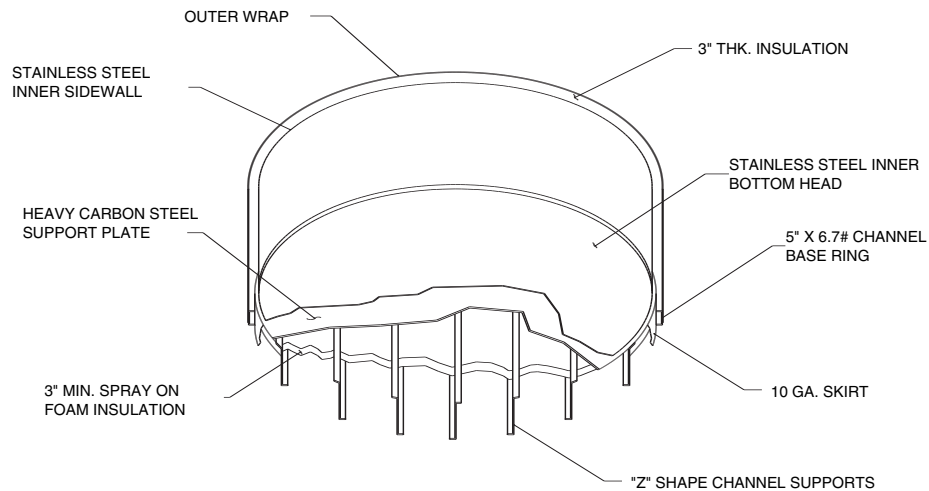

## SILO BOTTOM

### STANDARD

Flat Tank Bottom designed for placement on a flat concrete pad or steel structure.

- "Z" Rail design to distribute weight evenly.
- Undercoated with automotive type rust preventative.
- 9" standard outlet height, sump type
- Pitch 3/4" per foot.

### OPTIONS

- 9" standard, other outlet heights available
- Inlet and outlet on same horizontal plane
- Stainless steel base ring

## INNER LINER

### STANDARD

- T-304 SS #4 dairy finish

### OPTIONS

- T-316L SS
- #2 finish (if not designed to 3A spec)

## INSULATION

### STANDARD

- 3" Polystyrene Foam (scored to fit curvature of tank & banded to tank)
- Top Head - 3" fiberglass.
- Bottom - 3" min. thick urethane foam insulation.

## REINFORCING RINGS

### STANDARD

- Material, carbon steel, not welded to liner
- Thermal barrier between ring & tank liner
- Fiberglass insulation over rings, between rings & outer jacket

## OUTER JACKET

### STANDARD

- Material Carbon Steel prime painted with Tufcote gray primer #18565.

- Seismic Zone Calculated for zone 0, 1, 2, 3 & 4

### OPTIONS

- Stainless steel T304 light gauge lapped style, #3 finish side wall, #2 mill finish top head.
- Stainless steel T304 seal welded outer jacket
  - #2B mill finish, weld seams stripe buffed smooth, not flush, discoloration removed.
  - #2B mill finish weld seams - free hand buffed.
  - #3 finish, weld seams stripe buffed smooth, not flush, discoloration removed.
  - #3 finish, weld seams ground smooth
  - #2B mill finish, welded seams stripe buffed smooth.
- Finish paint, 2 coats, premium polyurethane, color selections available.



# S P E C I F I C A T I O N S F O R V E R T I C A L S I L O S

## HOLD DOWNS

### STANDARD

- Shipped with tank for field installation.
- Material, compatible with outer jacket material.
- Size - 12" channel and top plate with centered hole.
- Tank designed for welding to embedded anchor pads or ring in concrete.

## LIFTING LUGS

### STANDARD

- Quantity of 2 spaced at 180 degree around top head seam.
- Material compatible with outer jacket (lifting lugs included in base of silo)

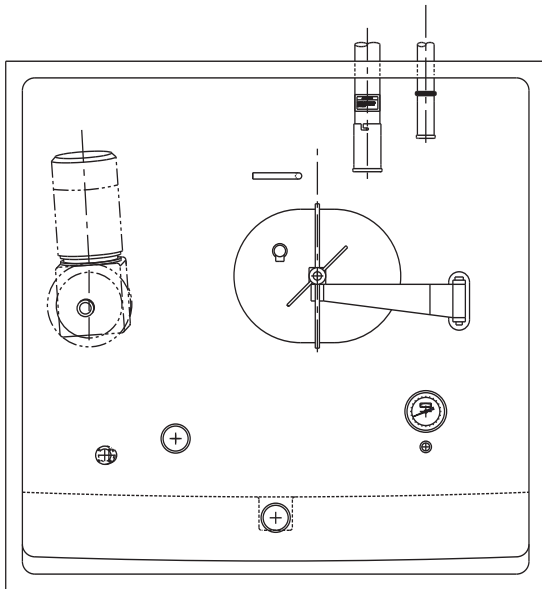

## ALCOVE

### STANDARD

- Material T304 stainless steel, #4 inside finish.
- Dimensions: 57-1/2" h x 60 - 3/4" w x 22" d, with flanged edge, Pitched bottom 2".

- Alcove welded on at factory
- Agitation 3 horsepower 141 rpm, 4 blade USDA approved cip design, optimum angle mounting.

### OPTIONS

- Insulated: 1" thick with 16 ga. stainless jacket (recommended alcove be welded with this option)
- Alcove shipped loose for field installation, pre-fit at factory, deduct available.
- Special alcove sizes available
- Contact factory for agitation options, including vertical configurations.

### Alcove Fittings

- Inlet Connection - offset to the left as facing outlet, 3" O.D.
- RTD well using 26P397 projectile well
- Level shell: Tank mate, Continental, Anderson, Rosemount please specify type.

## THERMOMETER

### STANDARD

- 5" dial type, 20 to 240 degree F, located in #1300 stainless steel projectile type well.

### OPTIONS

- Back angle style (Note: Projectile well will change to accommodate type)
- Customer requested thermometer
- RTD Recorder available on request

## MANWAY

### STANDARD

- Size - 16" x 20" elliptical
- Insulated
- Inside closing hinge style
- Channel type white neoprene gasket
- Custom fitted and numbered
- 1" spring loaded sampling valve in door
- Grab bar above manway



# S P E C I F I C A T I O N S F O R V E R T I C A L S I L O S

## OPTIONS

- Door gasket material:
  - EPDM or
  - Viton or
  - Nitrile
- Sampler Port
  - OMI tru-test sampler port located in door. (Note: This can be in addition to the Standard Sample Valve or in lieu of the Standard Sample Valve.)

## CLEAN-IN-PLACE (CIP SPRAY ARRANGEMENT)

- Klenzade SD-6 removable disc spray down located in top head center
- 90 GPM @ 20 psi. (Note: this unit provides cascade water flow & is drilled to direct water to the standard vent for cleaning of the vent line)
  - CIP & vent piping:
- 2" CIP line & 3" vent line, T304 SS, #4 finish from top of tank terminating in alcove extension.
  - Tri-clamp connection in alcove with screen & cap on 2" CIP line
  - Bayonet connection in alcove with screen and cap for 3" vent line
  - 3" x 2" interlock

## OPTIONS

- Spray Up Design
  - Located at near bottom of tank
  - Includes 2" tri-clamp connection in alcove area
  - GPM quoted based on silo capacity
- CIP Door
  - Stainless steel with HT/3C white neoprene gasket
- Walker spray dish with cross over to clean vent line.

## VENT

### STANDARD

- 3" #14 tri-clamp fitting
  - 3" 45 degree elbow, fill/empty rate 400 GPM to 3" line
- Note: Venting is a critical part of silo function. Improper vents can result in damage or tank collapse due to overfill. Fill and empty rate must be determined using proper number and

sizing of inlet/outlet connections. Most often high flow rates exist with large silos and raw product movement.

- Material - T304 stainless steel #4 finish
- Bayonet Connection in alcove
- Tri-clamp connection in alcove with screen and trap

## OPTIONS

- 4" 45 degree elbow sized for 700 GPM to 4" line
- 6" 45 degree elbow sized for 1600 GPM to 6" line
- Auxiliary vent line in addition to standard vent line located along side standard line with opening into tank at higher elevation than standard. Note, standard on cip spray up design.

## HEAT TAPE & INSULATION

### OPTIONAL ACCESSORIES

(Recommended in cold and possibly sub freezing weather conditions)

- Heat tape with Armaflex insulation on CIP and vent lines with PVC covers
- 120-volt operation
- Temperature switch provided

### ALSO AVAILABLE:

- Aluminum covering over insulation in lieu of PVC
- Alternative insulation in lieu of Armaflex

## HEAT TRANSFER PANELS

### OPTIONAL ACCESSORIES

- Omega Thermal Product laser style panel
- 304 stainless steel
- Proper size panels, welded to tank side wall. Proper sections are custom rolled to tank diameter. Connections - 2", 150# coupling, others on request.
- ASME UM code tested and stamped, standard
- ASME U stamp upon request
- Applications:
  - NH3 Thermal expansion systems
  - NH3 Full flooded systems
  - Refrigerant systems (depending on type)
  - Ice water
  - Hot water
  - Steam (depending on pressure)