

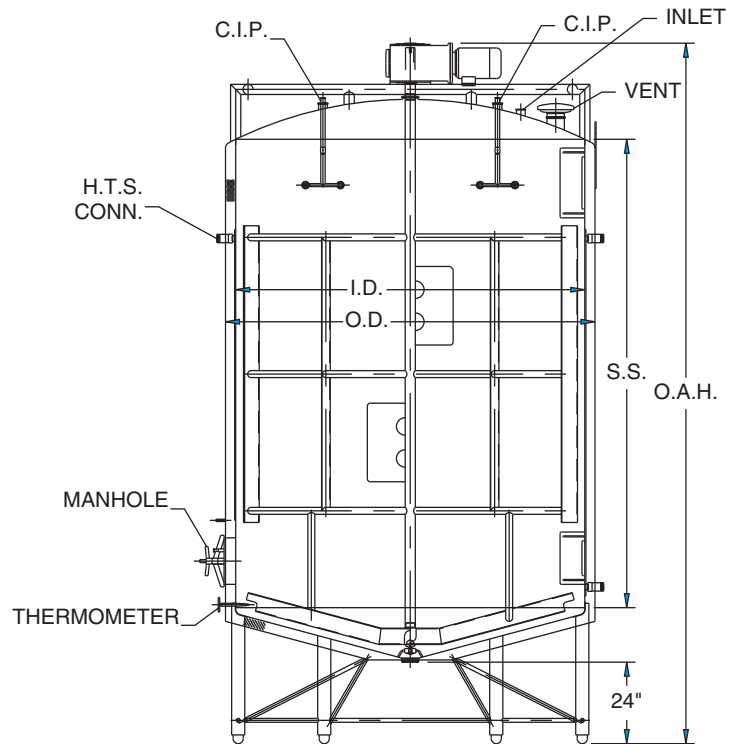

W H E Y C R Y S T A L I Z E R S P E C I F I C A T I O N S



STANDARD DIMENSIONS

Capacity US gallons	OAH Approx.	OD	ID	HTS Sq. Ft.
3,000	13'-3"	115"	108"	80
4,000	15'-3"	115"	108"	120
5,000	17'-3"	115"	108"	120
6,000	19'-3"	115"	108"	160
8,000	22'-8"	127"	120"	200
10,000	25'-8"	127"	120"	240
12,000	23'-6"	143"	136"	280
15,000	28'-7"	151"	144"	320
20,000	34'-7"	151"	144"	440



W H E Y C R Y S T A L I Z E R S P E C I F I C A T I O N S

MATERIALS

STANDARD

Flanged & Dished top head, 15° cone bottom head, 304 stainless steel polished to a #4 finish inside. Reinforcing rings on approximately 6' centers.

INSULATION

STANDARD

3" polystyrene insulation on sides and bottom, 3" fiberglass on top head.

OUTER JACKET

STANDARD

Heavy gauge 2B cold rolled stainless steel with welds striped and buffed.

MANHOLE

STANDARD

- 19" diameter, cam latched, hinged and gasketed stainless steel cover in top head on sizes less than 8,000 gallons.
- 16" x 21" insulated stainless steel inside closing door with gasket in sidewall of tanks 8,000 gallons and larger.

HEAT TRANSFER SURFACE

- Multiple zones with either internal or external manifolds for precise temperature balance, side wall and bottom head.
- Headers can be provided in stainless steel as an option.

LEGS

STANDARD

Stainless steel pipe legs with adjustable ball feet, concealed threads, and bracing between legs.

OUTLET

STANDARD

3" sanitary tri-clamp fitting in center of bottom cone head.

INLET

STANDARD

3" no-foam type tri-clamp fitting welded in top head.

AGITATION

STANDARD

Vertical top entering gate style with side and bottom sweep. Heavy-duty inverter rated gear motor for gentle agitation.

CIP

STANDARD

(2) removable spray ball units in top of tank (supply piping not included).

DIAL THERMOMETER

STANDARD

5" dial thermometer range from 20° to 240° with projectile well.

OPTIONS

STANDARD

Options:

- 2B Interior finish in lieu of #4
- 316L stainless steel liner
- Carbon steel outer jacket prime or finish painted
- Skirt with alcove and tunnel instead of legs for outside applications
- Bottom CIP spray ball for extra cleaning
- Inverter for maximum agitator flexibility and control
- Stainless Steel Ladder &/or Platform